

**Lecture Note -1**  
**Organic Chemistry CHE 502**  
**STEREOCHEMISTRY- I**

**Dr. SHALINI SINGH**  
**DEPARTMENT OF CHEMISTRY**  
**UTTARAKHAND OPEN UNIVERSITY**

---

# UNIT 1

## BASIC CONCEPTS OF STEREOCHEMISTRY

---

### Unit Structure

- 1.1 Introduction
- 1.2 Objectives
- 1.3 Stereochemistry- Definition
- 1.4 Terminology used in stereochemistry
- 1.5 Representation of three dimensional molecules
- 1.6 Element of symmetry
- 1.7 Nomenclature
- 1.8 Summary
- 1.9 Glossary
- 1.10 Check your progress
- 1.11 Bibliography
- 1.12 Suggested readings
- 1.13 Terminal Questions

---

### 1.1. INTRODUCTION:

---

Stereochemistry deals with three dimensional representation of molecule in space. This has sweeping implications in biological systems. For example, most drugs are often composed of a single stereoisomer of a compound. Among stereoisomers one may have positive effects on the body and another stereoisomer may not or could even be toxic. An example of this is the drug thalidomide which was used during the 1950s to suppress the morning sickness. The drug unfortunately, was prescribed as a mixture of stereoisomers, and while one stereoisomer actively worked on controlling morning sickness, the other stereoisomer caused serious birth defects.

The study of stereochemistry focuses on stereoisomers and spans the entire spectrum of organic, inorganic, biological, physical and especially supramolecular chemistry. Stereochemistry includes method for determining and describing these relationships; the effect on the physical or biological properties.

So to have the sound knowledge of stereochemistry we should have good command over their basic concepts.

---

## 1.2. OBJECTIVES:

---

- Classification of stereoisomers
  - Recognize a stereogenic (chiral) center in a molecular structure
  - Various representation of three dimensional molecules
  - To be able to predict, identify and distinguish between enantiomers and diastereomers.
  - Various nomenclature of stereoisomers to define them properly
- 

## 1.3. STEREOCHEMISTRY: DEFINITION

---

The branch of chemistry which deals with three dimensional structure of molecule and their effect on physical and chemical properties is known as stereochemistry. To represent molecule as three dimensional object we need at least one carbon  $sp^3$ - hybridized.

Example:

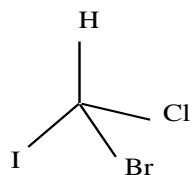

2D drawing Not appropriate for stereochemistry

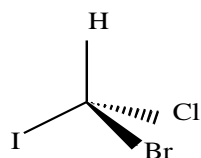

3D drawing appropriate for stereochemistry

---

## 1.4. TERMINOLOGY USED IN STEREOCHEMISTRY

---

### A. ISOMERS AND THEIR CLASSIFICATION

You are already familiar with the concept of isomers: different compounds which have the same molecular formula. Here we will learn to make distinction between various kinds of isomers, especially the stereoisomers.

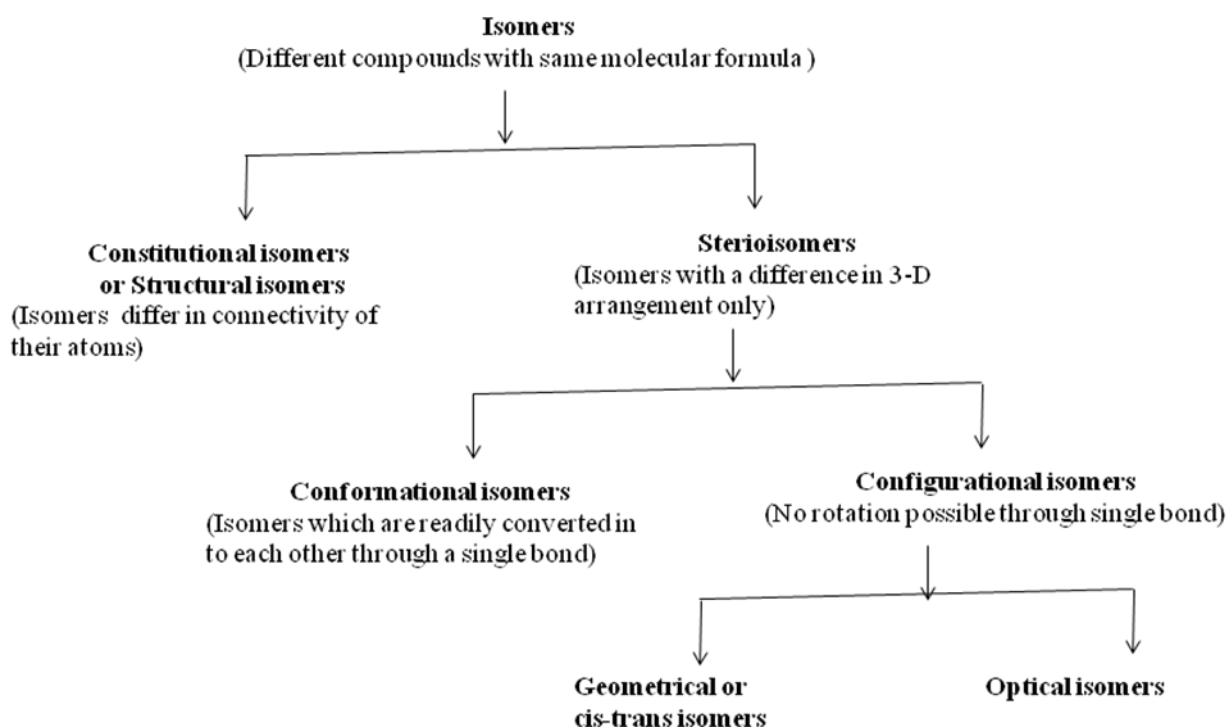

### B. OPTICAL ACTIVITY

We know that ordinary lights are composed of rays of different wavelengths vibrating in all directions perpendicular to the path of its propagation. These vibrations can be made to occur in a single plane by passing ordinary light through the polarizing Nicol prism. Such light whose vibrations occur in only one plane is called plane polarized light

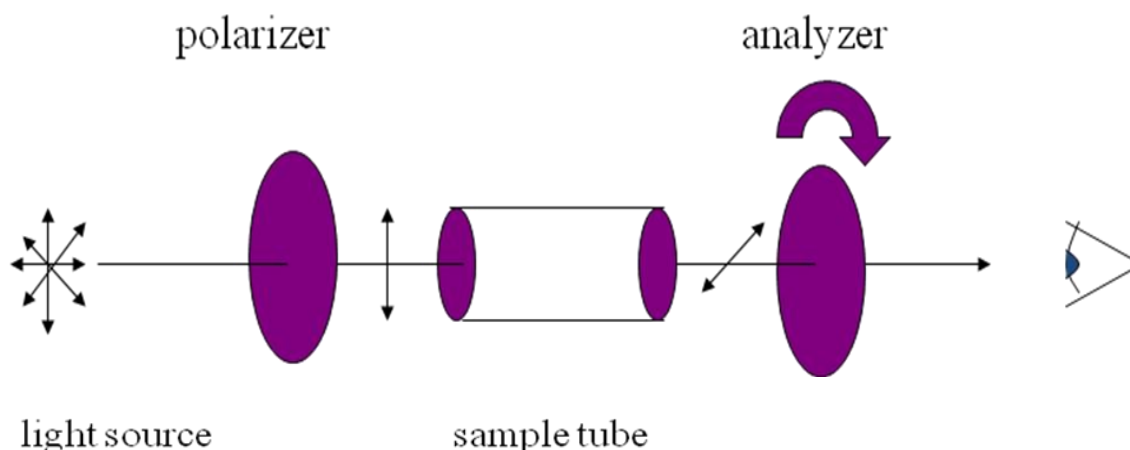

Compounds which rotate the plane of polarized light are called optically active compounds and this property is known as optical activity. Rotation of plane of polarized light can be of two types.

- **Dextrorotatory** : If the compound rotates the plane of polarization to the right (clockwise) it is said to be dextrorotatory (Latin: dexter-right) and is denoted by (+), or 'd'.
- **Laevorotatory** : If the compound rotates the plane of polarization to the left (anticlockwise) it is said to be laevorotatory (Latin: laevus-left) and is denoted by (-) or 'l'

The change in the angle of plane of polarization is known as optical rotation. The optical rotation is detected and measured by an instrument called polarimeter. The measurement of optical activity is reported in terms of specific rotation  $[\alpha]$ , which is given as,

$$[\alpha]_{\lambda}^t = \alpha/lc$$

$[\alpha]$  = specific rotation

t = temperature of measurement

$\lambda$  = wavelength of the light used

$\alpha$  = observed angle of rotation

l = length of sample tube in decimeter

c = concentration of the sample in g/mL of solution

## C. CHIRALITY

- **The term Chiral-** The word chiral (Greek word Chier, meaning hand) is used for those objects which have right-handed and left-handed forms, i.e., molecules which have "handedness" and the general property of "handedness" is termed chirality. An object which is not superimposable upon its mirror image is chiral.

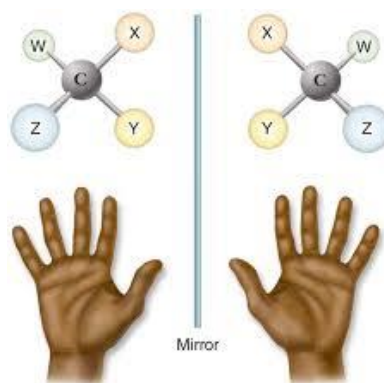

- **The term Achiral-**

Object and molecules which are superimposable on their mirror images is achiral. Achiral molecule has internal plane of symmetry, a hypothetical plane which bisects an object or molecule into mirror-reflective halves. An object or molecule with an internal plane of symmetry is achiral.



- **The term Asymmetric center and chiral center-** Three terms are used to designate, a carbon atom bonded tetrahedrally to four different substituents in a chiral molecule: Asymmetric atom, chiral center or stereocenter.

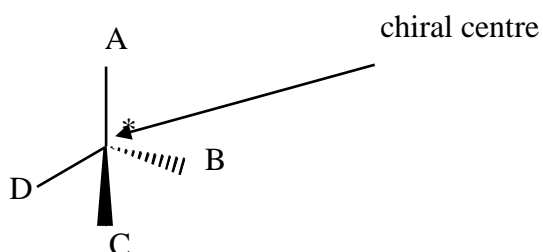

Let us understand chiral and achiral center taking few more examples.

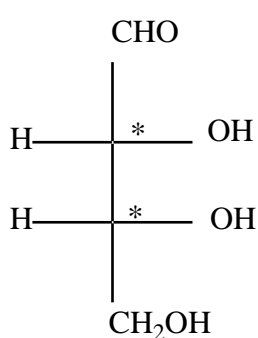
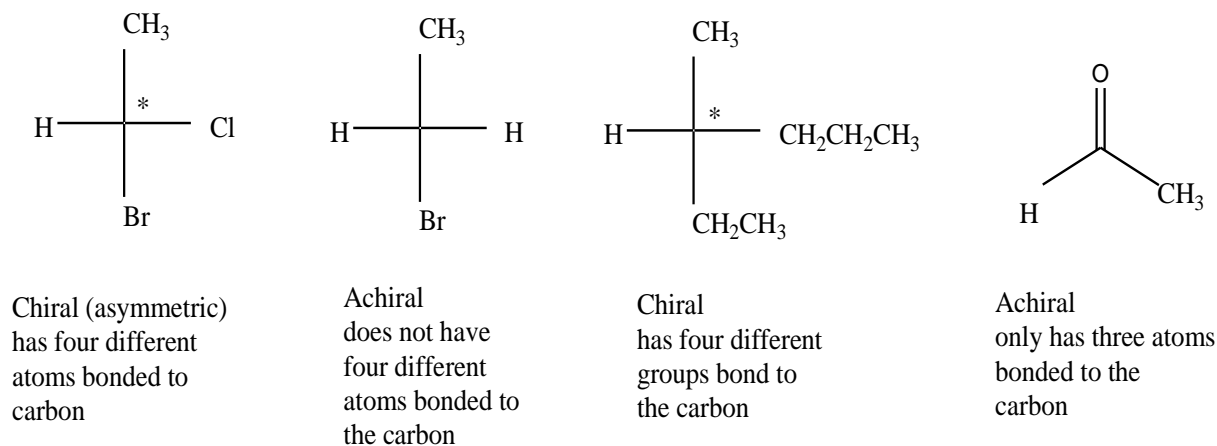

Chiral  
with two chiral centre

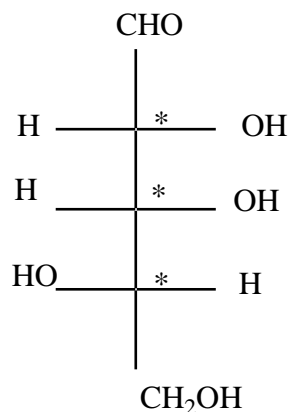

Chiral  
with three chiral centre

Chiral centres are shown by astrik (\*)

- The term stereogenic center or stereocenter-**

A stereogenic center is defined as an atom on which an interchange of any two atoms or groups result in a new stereoisomer, When the new stereoisomers is an enantiomer ,the stereocenter is called chiral center. All stereocenters are not tetrahedral.

Example 1

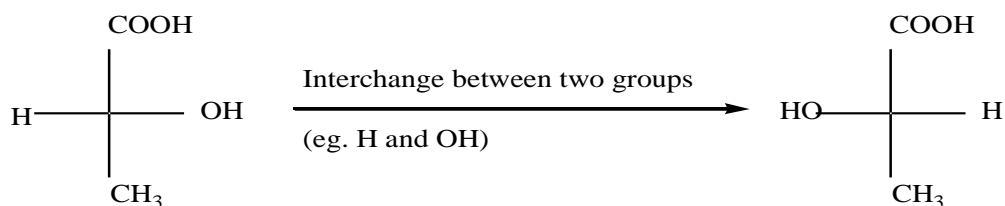

Stereocentre  
I

New Stereoisomer  
II

First and second are enantiomers (non superimposable mirror images), Hence the stereiocentre is a chiral centre

### Example-2

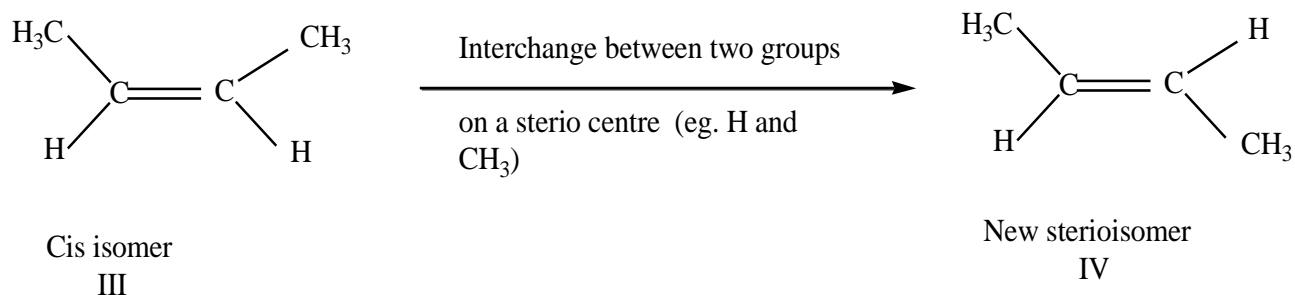

III and IV are not enantiomers. They are diastereomers; hence, in this case, stereocenters are not chiral centers. Also, these are not tetrahedral.

Thus, all chiral centers are stereocenters, but all stereocenters are not chiral centers. If a molecule contains only one chiral center, it must be chiral. A molecule containing two or more chiral centers may or may not be chiral. For example, meso-tartaric acid has two chiral centers but is achiral.

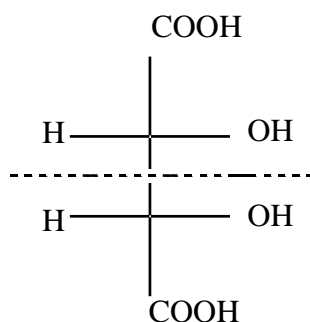

Achiral due to presence of plane of symmetry

**D. STEREOISOMERS-** Isomers having the same molecular formula but different spatial arrangement of their atoms are known as stereoisomers. They are of the following types:

- **Enantiomers:** Stereoisomers which are non-superimposable mirror images of each other are called enantiomers. Chirality is a necessary and sufficient condition for the existence of enantiomers. These always exist as discrete pairs.

Eg.

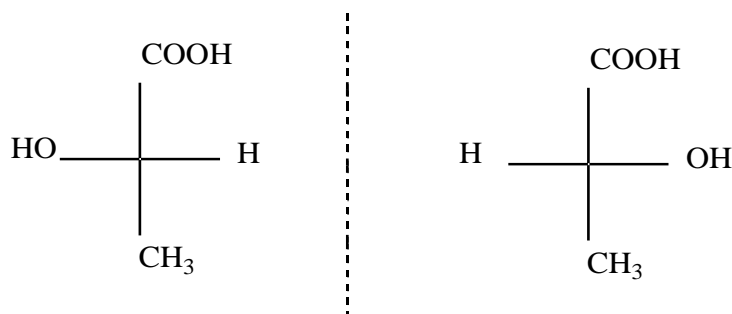

Two isomers of Lactic acid



- **Diastereomers:** Stereoisomers that are not mirror images of each other are called diastereomers.

Example.

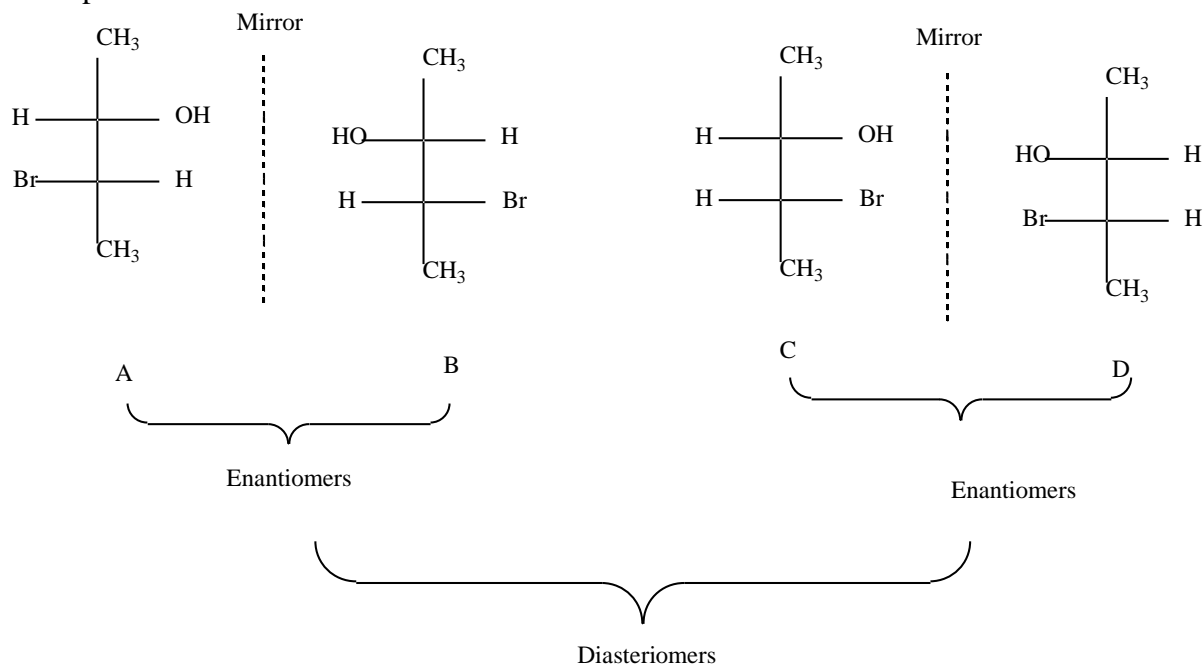

Four isomers of 3-Bromo-2-butanol

- **Geometrical Isomers:**

Geometrical isomers occur as a result of restricted rotation about a carbon-carbon bond. This is also called cis-trans isomerism.

This isomerism is exhibited by a variety of compounds such as compounds containing double bonds C=C, C=N, N=N, compounds containing cyclic structures or compounds containing restricted rotation due to steric hindrance.

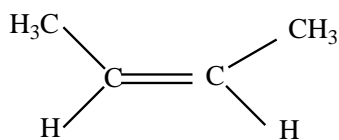

Cis isomer

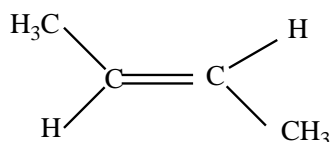

Trans isomer

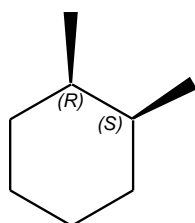

Cis isomer

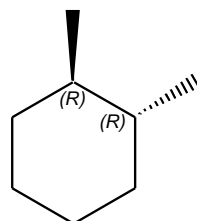

Trans isomer

- **Conformational isomers:** Conformational isomers are the isomers that can be converted into one another by rotation around a single bond.

Example: eclipsed, gauche and anti butane are all conformational isomers of one another. (eclipsed means that identical groups are all directly in line with one another, gauche means that identical groups are 60 degree from one another and anti means that identical groups are 180 degree from one another.)

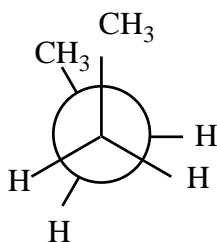

Eclipsed

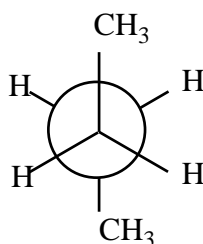

Anti

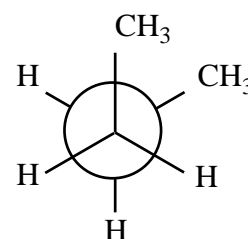



Gauche

These molecules can be interconverted by rotating around the central carbon-carbon single bond.

## 1.5. REPRESENTATION OF THREE DIMENSIONAL MOLECULES

### 1.5.1 FLYING-WEDGE OR WEDGE-DASH PROJECTION

The Flying-Wedge Projection is the most widely used three dimensional representation of a molecule on a two dimensional surface (paper). This kind of representation is usually done for molecule containing chiral centre. In this type of representation three types of lines are used.

- A solid wedge or thick line (  ) - it represents bond projection towards the observer or above the plane of paper.
- A continuous line or ordinary line (  ) - it represents bond in the plane of paper.
- A dashed wedge or broken line (  ) - it represents bond projection away from the observer or below the plane of paper. Example:- CH<sub>4</sub> (methane)

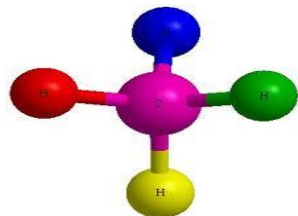

“Ball and stick” model  
of 3-D structure of methane

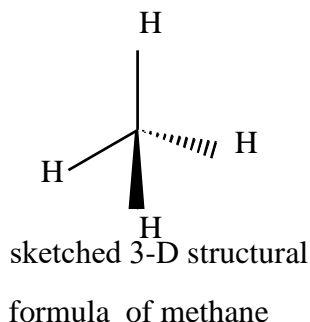

## 1.5.2 FISCHER PROJECTION

Fischer projection provide an easy way to draw three dimensional molecule on two dimensional paper and all the bonds are drawn as solid lines around asymmetric carbon atom.

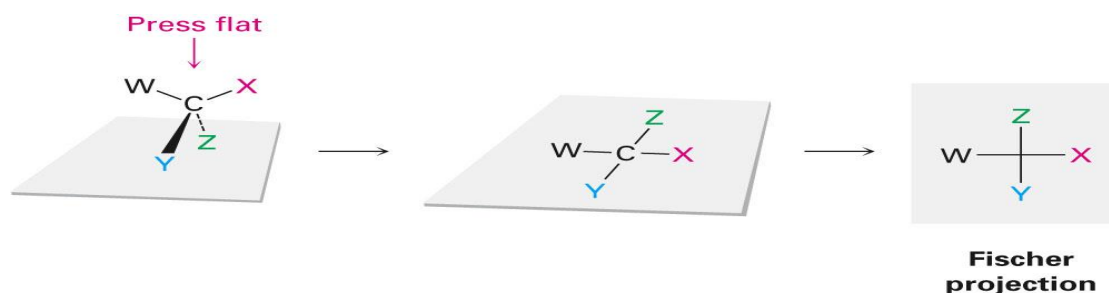

The Fischer rules for showing the arrangement around asymmetric carbon.

- The carbon chain of the compound is projected vertically, with the most oxidized carbon at the top or place the carbon number one at the top (as defined by nomenclature rule).
- The chiral carbon atom lies in the plane of the paper and usually omitted. The intersection of cross lines represents asymmetric carbon.
- The horizontal bonds attached to the chiral carbon are considered to be above the plane of paper or point towards the observer.
- The vertical bonds attached to the chiral carbon are considered to be below the plane of paper or point away from the observer.

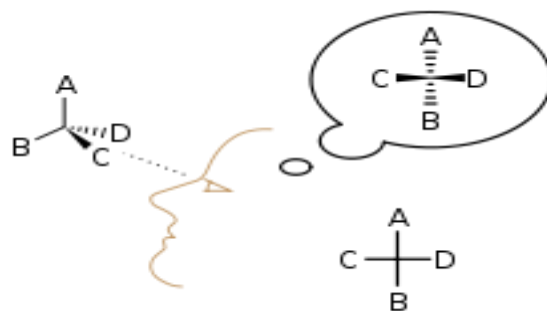

Example: glyceraldehyde

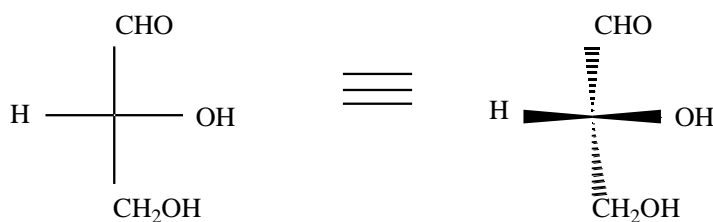

### 1.5.3 SAWHORSE FORMULA

The sawhorse formula indicates the arrangement of all the atoms or groups on two adjacent carbon atoms. The bonds between the two carbon atoms are drawn diagonally and of relatively greater length for the sake of clarity. The lower left hand carbon is taken as the front carbon or towards the observer and the upper right hand carbon as the back carbon or away from the observer. e.g. ethane

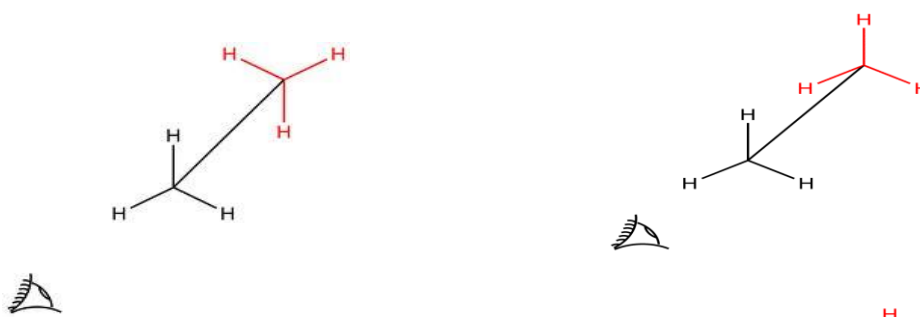

Anti conformation

eclipsed conformation

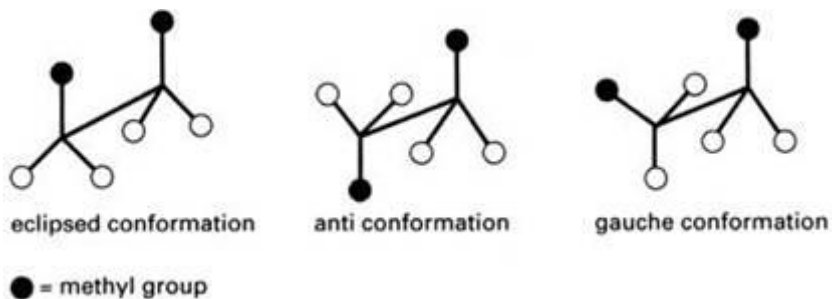

All parallel bonds in sawhorse formula are eclipsed and all anti parallel bonds are opposite or scattered. Gauche representation is that in which bulky groups are nearer to each other at  $60^{\circ}$  angles.

### 1.5.4 NEWMAN PROJECTION

Newman devised a very simple method of projecting three dimensional formulas on two dimensional paper which are known as Newman projection.

- In these formulae the molecule is viewed from the front or along the axis of a carbon-carbon bond.
- The carbon nearer to the eye is represented by a point and the carbon atom towards the rear by circle.
- The three atoms or groups on the carbon atoms are shown as being bonded to dot or circle by an angle of  $120^{\circ}$  to each other.
- In Newman formula all parallel bonds are eclipsed or all anti parallel or opposite bonds are staggered.

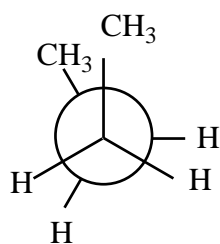

Eclipsed

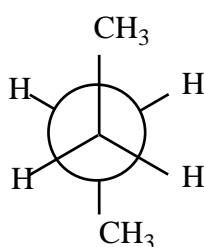

Anti

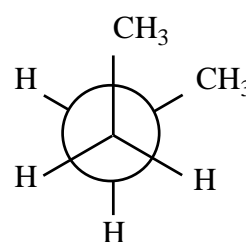

Gauche

---

## 1.6 ELEMENTS OF SYMMETRY

---

Elements of symmetry offer a simple device to decide whether a molecule is chiral or achiral, *i.e.*, whether it is superimposable on its mirror image or not. When a molecule has no plane of symmetry, no centre of symmetry and no alternating axis of symmetry, it is non superimposable on its mirror image and is chiral (optically active).

### 1.6.1 PLANE OF SYMMETRY

The plane which divides a molecule in to two equal halves which are related as object and mirror image is known as plane of symmetry. For example

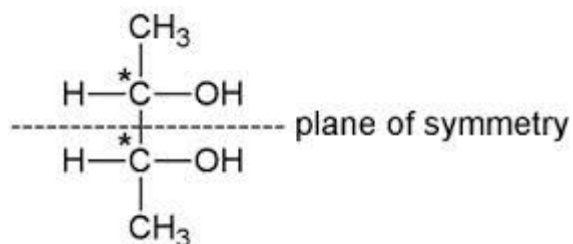
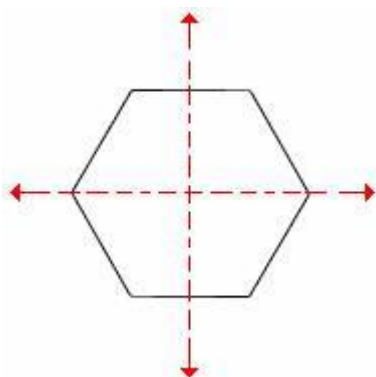

The molecules having plane of symmetry are achiral (optically inactive).

## 1.6.2 CENTER OF SYMMETRY

A center of symmetry in a molecule is said to exist if a line is drawn from any atom or group to this point and when extended to an equal distance beyond this point, meets the identical atom or group.

All lines are passing through this point, hence it is the center point of the molecule.

A centre of symmetry is usually present only in an even number ring. For example, the molecule of trans -2,4-dimethyl-cyclobutane –trans-1,3- dicarboxylic acid has a center of symmetry.

(All lines are passing through this point, hence it is the center point of the molecule)

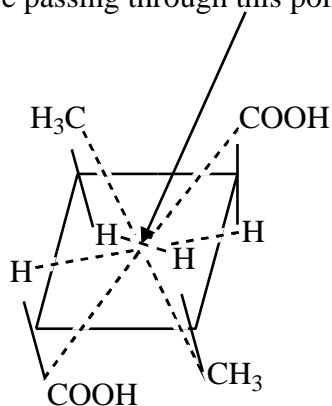

I

Another interesting example is dimethyl ketopiperazine. This has two isomers, cis and trans. The cis form has no plane of symmetry or centre of symmetry. The trans form on other hand, has a centre of symmetry.

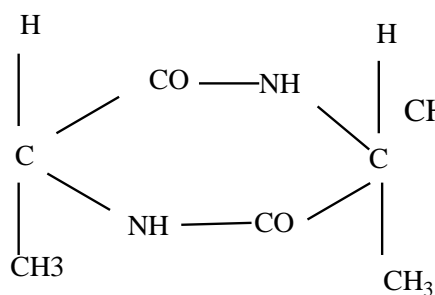

CO-CO and NH-NH are symmetrical but  
CH<sub>3</sub> and H are not mirror images i.e.,  
not symmetrical with respect to centre point.

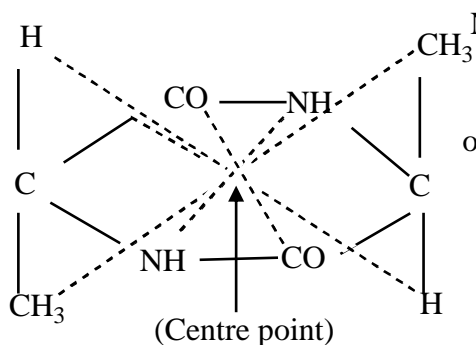

NH-NH, CO-CO, CH<sub>3</sub> - CH<sub>3</sub> and H-H  
they are symmetrical with respect to centre  
of the molecule.

### 1.6.3 ALTERNATING AXIS OF SYMMETRY

A molecule possesses an alternating axis of symmetry if, when rotated through an angle  $360^\circ/n$  about this axis and then followed by reflection in a plane perpendicular to the axis, the molecule is indistinguishable from the original molecule. Alternating axis of symmetry is rare and can be present in cyclic as well as open chain compounds.

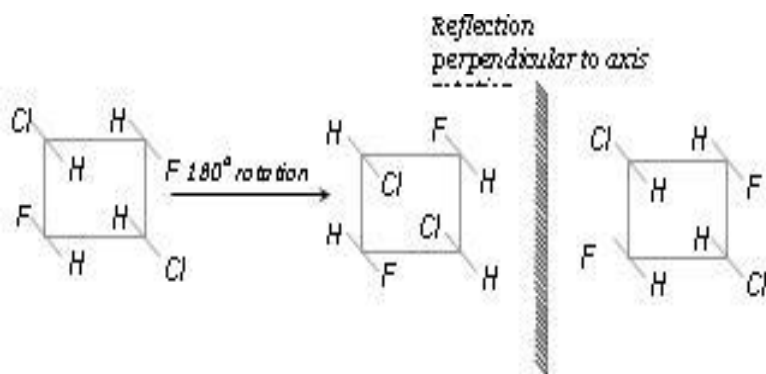

---

## 1.7 NOMENCLATURE OF OPTICAL ISOMERS

---

Following three nomenclatures are used for optically active compounds:

### 1.7.1 D, L SYSTEM OF NOMENCLATURE

This nomenclature is mainly used in sugar chemistry or optically active polyhydric carbonyl compounds. This is a relative nomenclature because all the configurations described with respect to glyceraldehydes.

All sugars whose Fischer projection formula shows the OH group on the right hand side of the chiral atom belong to the D-series.

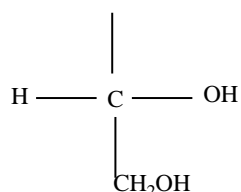

D-series.

Similarly, if OH is on the left hand side, then the sugar belongs to the L-series.

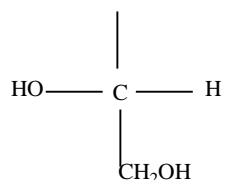

L-series

Examples:

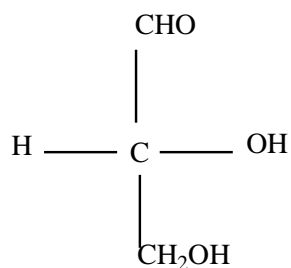

D(+) glyceraldehyde

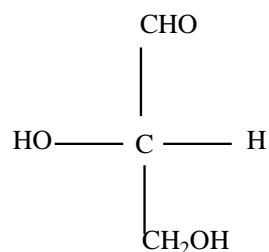

L(-) glyceraldehydes



- It must be noted that there is no relation between sign of rotation and (+, - or *d,l*) and configuration (D and L) of enantiomer.
- Any compound that can be prepared from, or converted in to D(+) glyceraldehydes will belong to D-series and similarly any compound that can be prepared from, or converted in to L(-) glyceraldehydes will belongs to the L-series.

### 1.7.2 *ERYTHRO* AND *THREO* SYSTEM OF NOMENCLATURE

This nomenclature is mainly used only in those compounds which have only two chiral carbons and the following structures:

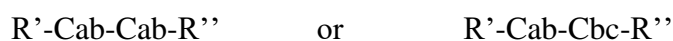

*i.e.* out of six substituent on two asymmetric carbons, at least one should be same in both the carbons.

When two like groups in fisher projection formula are drawn on the same side of vertical line, the isomer is called *erythro* form; if these are placed on the opposite sides the isomer is said to be *threo* form.

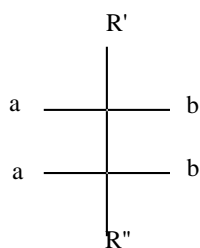

*erythro* form

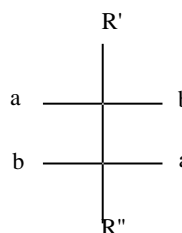

*threo* form

Following are some examples of *threo* and *erythro* form.

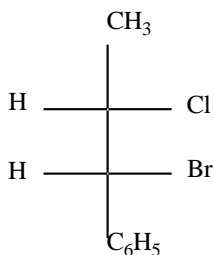

*erythro* form

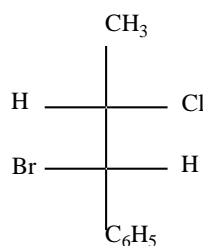

*threo* form

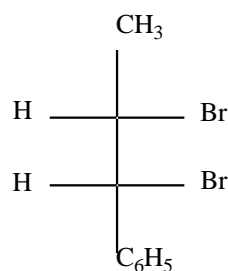

*erythro* form

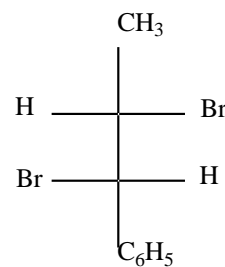

*threo* form

### 1.7.3 R.S. NOMENCLATURE

The order of rearrangement of four groups around a chiral carbon is called the absolute configuration around that atom. System which indicates absolute configuration was given by three chemists R.S. Cahn, C.K. Ingold and V. Prelog. This system is known as (*R*) and (*S*) system or the Cahn-Ingold Prelog system. The letter (*R*) comes from the Latin rectus (means right) while (*S*) comes from the Latin sinister (means left). Any Chiral carbon atoms have either an (*R*) configuration or a (*S*) configuration. Therefore one enantiomer is (*R*) and the other is (*S*). A racemic mixture may be designated as (*RS*), meaning a mixture of the two.

The R, S nomenclature involves two steps:

**Step I:** The four ligands (atom or groups) attached to the chiral centre are assigned a sequence of priority according to sequence rules.

**Rule 1:** If all the four atoms directly attached to the chiral carbon are different, priority depends on their atomic number. The atom having highest atomic number gets the highest priority, i.e., (1). The atom with lowest atomic number is given lowest priority, i.e. (2), the group with next higher atomic number is given the next higher priority (3) and so on.

For example:

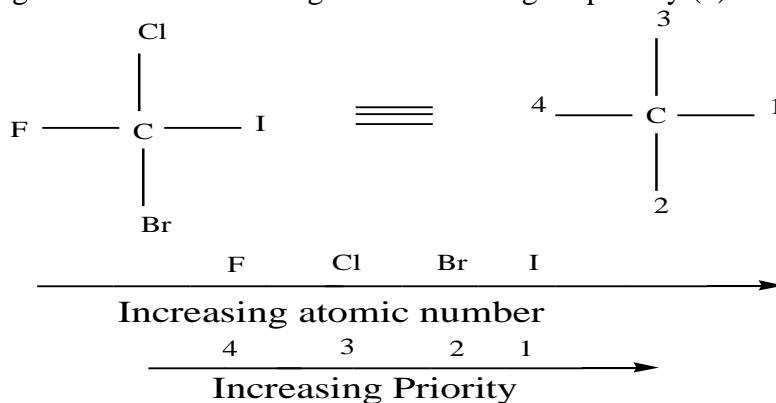

**Rule 2:** if two or more than two isotopes of the same element are present, the isotope of higher mass receives the higher priority.

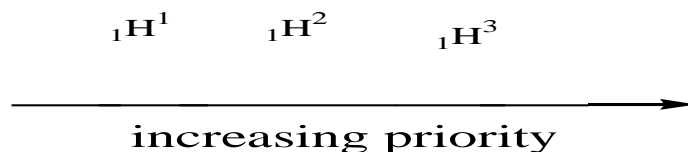

**Rule 3:** if two or more of the atoms directly bonded to the chiral carbon are identical, the atomic number of the next atom is used for priority assignment. If these atoms also have identical atoms attached to them, priority is determined at the first point of difference along the chain. The atom that has attached to it an atom of higher priority gets the higher priority.

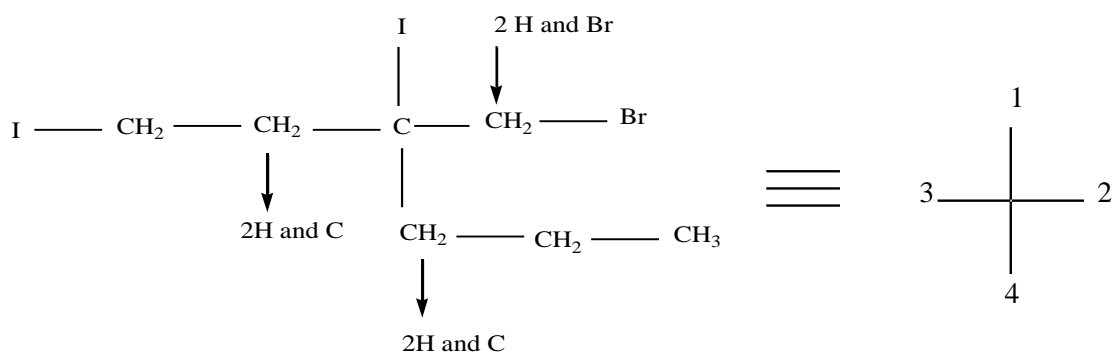

- In the above example, the atoms connected directly to the chiral carbon are iodine and three carbons.
- Iodine has the highest priority.
- Connectivity of other three carbons are  $2\text{H}$  and  $\text{Br}$ ,  $2\text{H}$  and  $\text{C}$  and  $2\text{H}$  and  $\text{C}$ .
- Bromine has the highest atomic number amongst  $\text{C}$ ,  $\text{H}$ ,  $\text{Br}$  and thus  $\text{CH}_2\text{Br}$  has highest priority among these three groups (*i.e.* priority number 2).
- The remaining two carbon are still identical ( $\text{C}$  and  $2\text{H}$ ) connected to the second carbon of these groups are  $2\text{H}$  and  $\text{I}$  and  $2\text{H}$  and  $\text{C}$ . Iodine has highest priority.
- Amongst these atoms, so that  $\text{-CH}_2\text{-CH}_2\text{-I}$  is next in priority list and  $\text{CH}_2\text{-CH}_2\text{-CH}_3$  has the last priority.

**Rule 4:** If a double or a triple bond is linked to chiral centre, the involved electrons are duplicated or triplicated respectively.

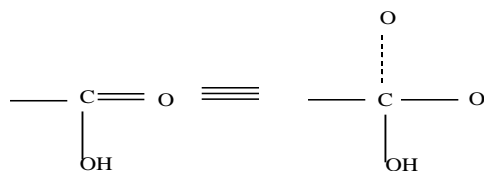
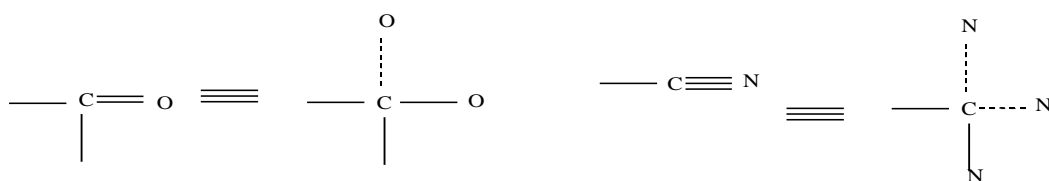

- By this rule, we obtain the following priority sequence:

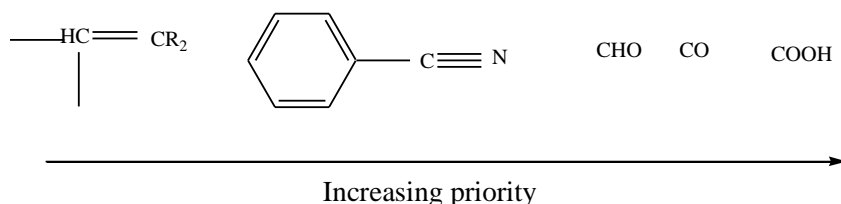

**STEP-II:** The molecule is then visualised so that the group of lowest priority (4) is directed away from the observer (at this position the lowest priority is at the bottom of the plane). The remaining three groups are in a plane facing the observer. If the eye travels clockwise as we look from the group of highest priority to the group of second and third priority (i.e.  $1 \rightarrow 2 \rightarrow 3$  with respect to 4) the configuration is designated R. If arrangement of groups is in anticlockwise direction, the configuration is designated as S.

For example:

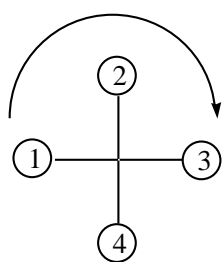

Clockwise arrangement of  
 $\textcircled{1} \textcircled{2}$  and  $\textcircled{3} \rightarrow \mathbf{R}$

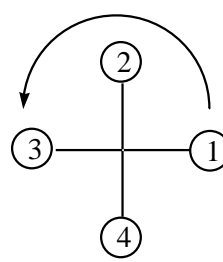

Anticlockwise arrangement of  
 $\textcircled{1} \textcircled{2}$  and  $\textcircled{3} \rightarrow \mathbf{S}$

Let us apply the whole sequence to bromochlorofluoromethane.

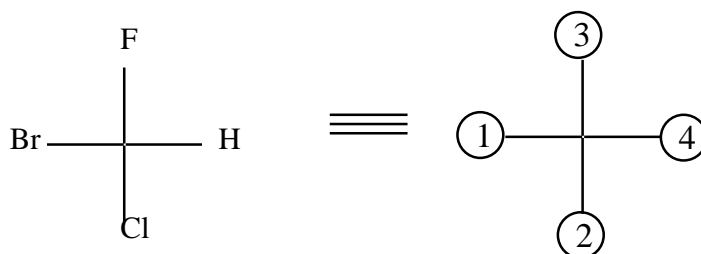

In this Fischer projection, the least priority number is not at the bottom of the plane.

In such cases, the Fischer projection formula of the compound is converted in to another equivalent projection formula in such a manner that atom the lowest priority is placed vertically downward. This may be drawn by two interchanges between four priority numbers. The first interchange involves the two priority numbers, one is the least priority number and the other is the priority number which is present at the bottom of the plane. In the above case, first interchanges will takes place between 2 and 4.

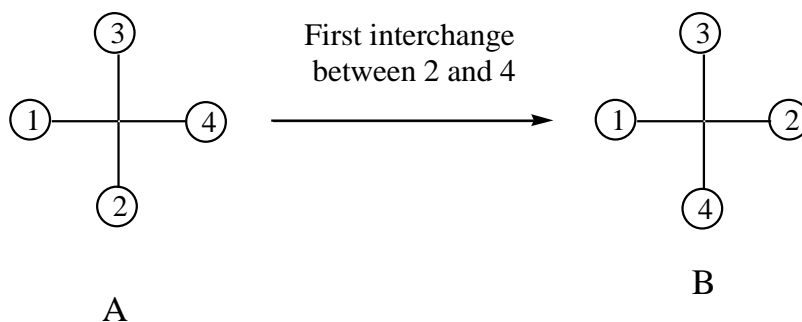

A second inter change creates the original molecule (i.e. A).

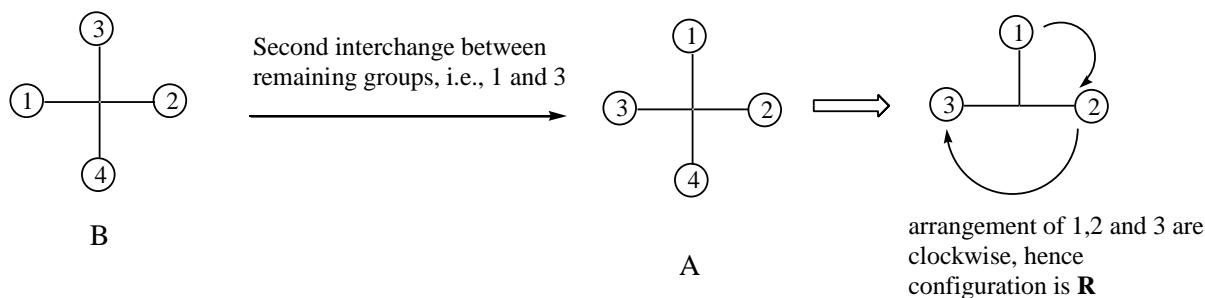

Example:-

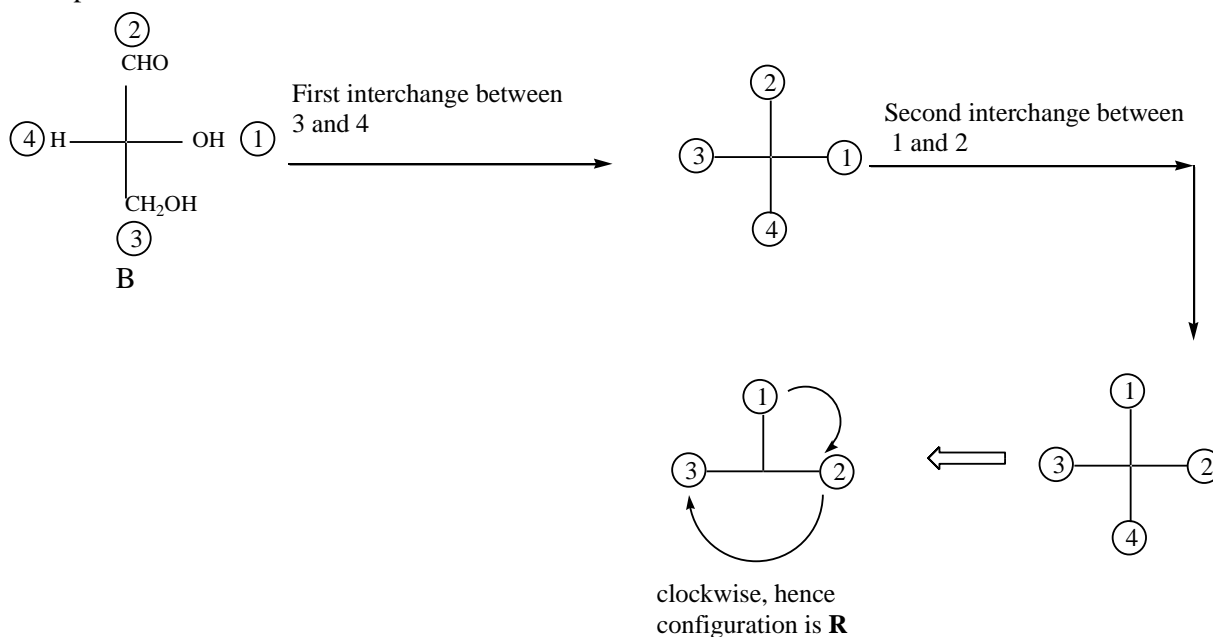

Note:-

- An odd number of interchange of positions of groups on chiral carbon gives different compound.
- An even number of interchange of positions of groups on chiral carbon gives same compound.

**An alternative, simple and most widely accepted procedure used now (Epling,1982) to assign R,S configuration in the case of Fischer projections is as follows:**

**Case-I: R and S nomenclature from Fischer projection formula (Golden rule):** If in a Fischer projection, the group of lowest priority (4) is on a vertical line, then the assignment of configuration is R for a clockwise sequence of 1 to 2 to 3 and S for anticlockwise sequence.

For example:

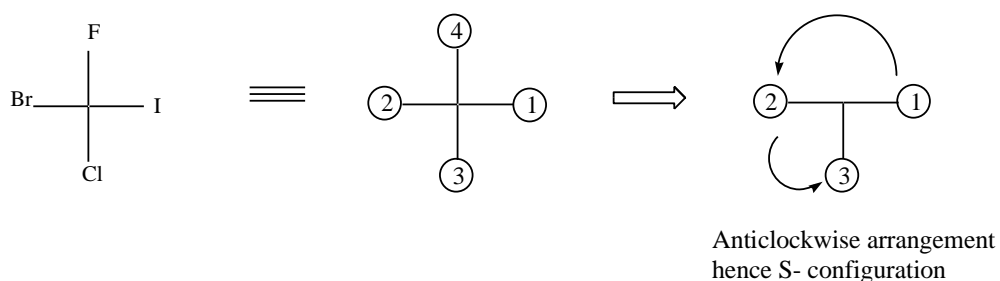

However, if the group of lowest priority is on horizontal line, then the assignment of configuration is S for a clockwise sequence of 1 to 2 to 3, and R for the anticlockwise sequence.

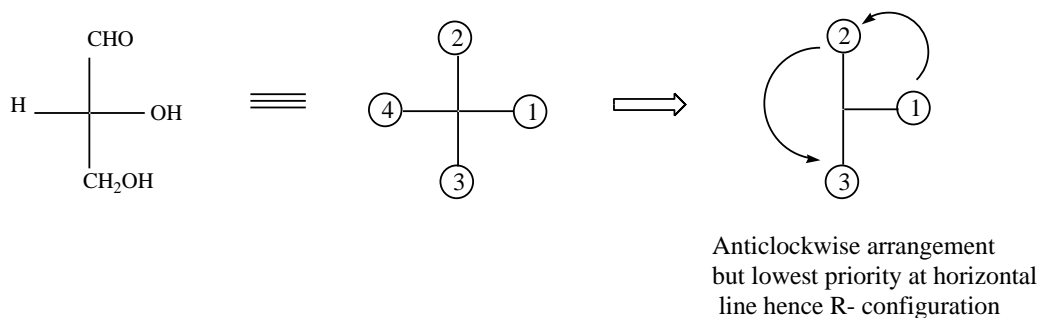

When molecule contain two or more chiral centres, each chiral centre is assigned an R or S configuration according to the sequence and conversion rules. Thus (+) tartaric acid is (2R, 3R) (+) tartaric acid.

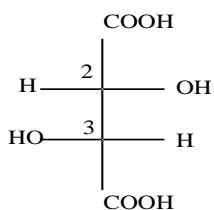

Configuration at chiral carbon - 2.

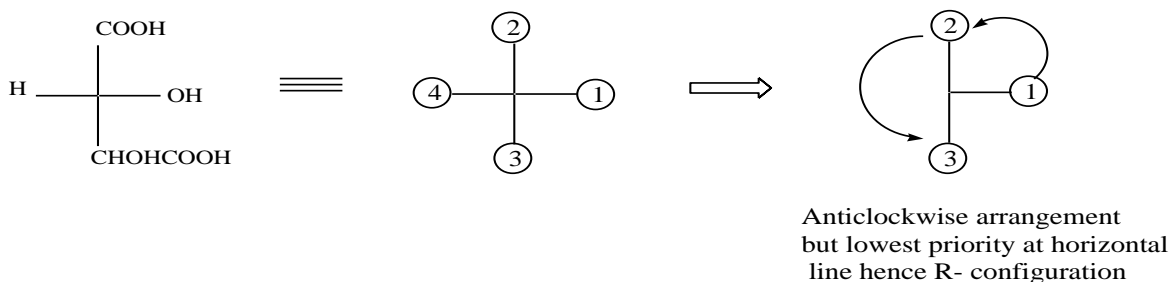

Configuration at chiral carbon - 3.

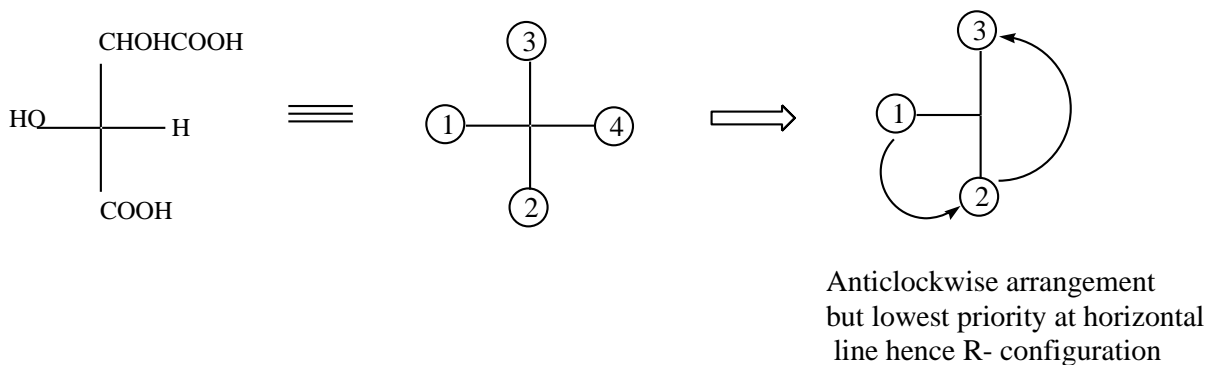

### Case-II: R, S- nomenclature from flying-wedge formula.

- If the group of the lowest priority is away from the observer (i.e., bonded by dashed line) and the priority sequence (1 → 2 → 3) is clockwise, then the configuration is assigned as R. If the priority sequence is anticlockwise then the configuration is S.

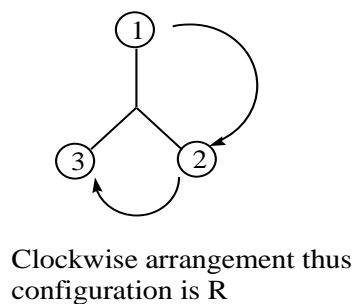
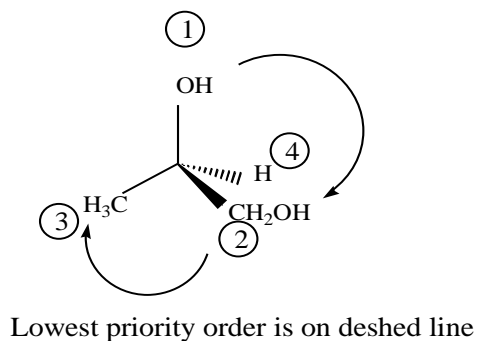

- If the group of lowest priority is not bonded by dashed line then interchange a pair of groups so that the group with the lowest priority is bonded by dashed line. Now see the sequence (1 → 2 → 3), if it is clockwise then the configuration is assigned as S and if anticlockwise R. This is because you have interchanged a pair of groups and now you are determining the configuration of enantiomer of original molecule.

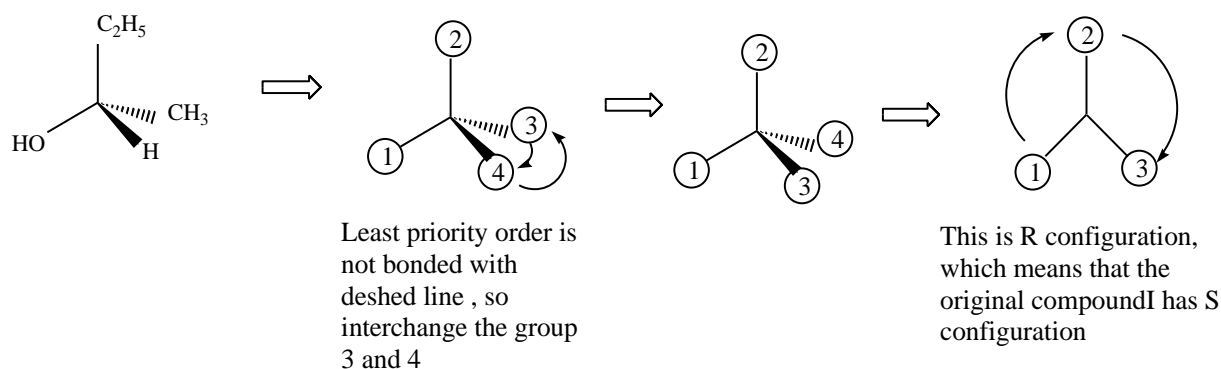

## 1.8 SUMMARY

In this unit we have discussed the various basic terms used in stereochemistry and necessary conditions which are important for any molecule to show stereoisomerism. Further we studied various kinds of three dimensional representations and their nomenclature and brief description of element of symmetry.

## 1.9 GLOSSARY

**Asymmetric carbon** is a carbon atom that is bonded to four different groups. It is also called *chiral carbon*.

**Diastereomers** are optical isomers that are not mirror images.

**Enantiomers** are optical isomers that are mirror images.

**Meso Compound** is a compound that has more than one asymmetric carbon and that is superimposable on its mirror image. Meso compounds are optically inactive.

**Optically active molecule** is a molecule that cannot be superimposed on its mirror image. It is also called chiral molecule.



### 1.10 *CHECK YOUR PROGRESS*

1. Define the term 'Stereochemistry'.
2. Explain the terms 'Chirality' and 'Achirality'.
3. What do you understand by the term 'Stereogenic center'?
4. Explain 'Stereoisomers'
5. Explain 'Element of Symmetry'.

### 1.11 *BIBLIOGRAPHY*

Kalsi, P.S. (2007), Stereochemistry Conformation and Mechanism, New Age International(P) Limited, Publishers, New Delhi.

Singh, J. and Yadav, L.D.S. (2013) Organic Chemistry Vol-I, A Pragati Prakashan, Meerut.

Nasipuri, D. (2012) Stereochemistry of organic Compounds, New Academic Science, UK.

Bahl, A. and Bahl, B.S. (2011) A Text Book of Organic Chemistry, S. Chand Publisher, New Delhi.

### 1.12 *SUGGESTED READINGS*

Christian Wolf (2007), Dynamic Stereochemistry of Chiral Compounds, Royal Society of Chemistry.

Eliel E.L., Samuel H. W., Stereochemistry of Organic Compounds. Wiley.

### 1.13 *TERMINAL QUESTIONS*

1. How many chiral atoms does the following molecule have?

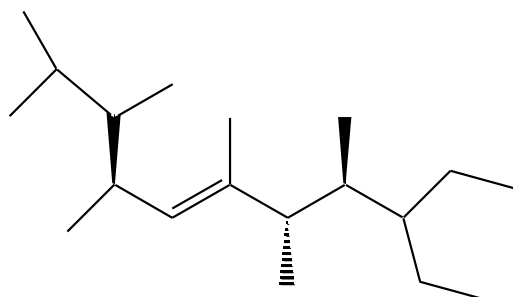

2. What is the stereochemical relationship between the following two molecules?

